

Ultrasonic Detectors in Space

By George Studor, Johnson Space Center/Structural Engineering Division
May 22, 2002

What happens when a micrometeoroid penetrates the International Space Station? The atmospheric pressure in the cabin is dropping, but where's the hole? Years of experience with hand-held Ultrasonic tools has shown them to be effective in identifying a number of maintenance problems including just this scenario, yet until STS-104 in July 2001, the astronaut crews had no tools to help them quickly locate leaks of their precious air!!

How did it start?

While several Ultrasonic Detectors have been evaluated over the International Space Station development period, none have gotten approved for funding to be placed on orbit. As the Shuttle mission to deliver and assemble the ISS Airlock approached, mission operators in Houston began to get nervous. Space Station Mission Operations and Environmental Control/Life Support Systems experts felt that the installation and activation of the Space Station Airlock could have problems with the many pressure lines to connect and seals to be established on the STS-104/ISS 7A mission.

In February 2001, an effort was begun to find a leak-locating tool that was simple yet effective for the astronauts to use and could be certified in time to fly on STS-104 planned for June. Fortunately, the Johnson Space Center (JSC) Structural Engineering Division (ES), Mission Opera-

tions Directorate (DF53) and JSC Facilities Operations Directorate (JA), funded by the Center Director's Discretionary Fund, were about to conduct a vacuum chamber test and evaluation of an ultrasonic inspection tool used to perform facility inspections. The simpler system made by CTRL Systems, the UL101, was added to the test and selected by the evaluation team, that included representatives of the astronaut office, to be certified and prepared for manifesting.

What is the ULD?

The Ultrasonic Leak Detector (ULD) kit, made by CTRL Systems, Inc. (www.ctrlsys.com), has a simple battery-powered ultrasonic (40KHz) receiver that provides a corresponding audible representation of the level of Ultrasonic noise into a high quality headset. Various attachments allow the microphone to have varying degrees of focus. There is an attachment that also allows the user to detect ultrasound transmitted through structure such as sensing fluid flow-by of an internally leaking valve in a pipe. A transmitter is available to flood a cavity that is supposed to be sealed, to determine if any leaks are present without pressurizing the cavity with air or fluid. Other attachments to the ULD allow the device to discern the condition of bearings, gears, seals, and valves, as well as identify corona discharge to ground and electrical discharge -- making the ULD a valuable tool in

locating mechanical and electrical failures, in addition to leak detection.

What happened next?

JSC Structures Engineering Division went right to work procuring and certifying the hardware, preparing the formal requests for space-flight and addressing the safety certification. The Mission Operations In-flight Maintenance



Above: ULD and components

team had been training the astronaut crews for several months on the use of Ultrasonic Detectors and now they went into high gear, preparing a training CD on the CTRL Systems hardware for the on-orbit training of the astronauts. All that remained was to find a small space to put the hardware on the Space Shuttle trip up. Shortly after room for the ULD was found, manifesting pressures arose including problems with the Station's treadmill system required immediate spare parts be put on the Space Shuttle. The priorities of what equipment was required to be onboard had to be re-examined and even some of the already approved equipment would have to be bumped! The ULD made the cut and was ready in the packing area with safety sign-off just in time for packing and shipping to Kennedy Space Center.

ULD earns its keep.

With STS-104's successful launch on July 12th, 2001, the ULD was transferred to the ISS.

Safely on-board, there was little to do but wait for an event that might need troubleshooting - and it didn't take long!! The Airlock was installed and pressurization integrity checks began for the outboard "crew lock" portion of the Airlock...but pressure was not holding and there was no indication of why. The timeline for the mission was especially packed with work and any delays to the first space-walk would have significant impacts to the mission. As the ground crews confirmed the indications were real, they radioed the crew to break out the ULD - then communications contact was lost. A few minutes later, when the LOS (Loss of Signal) was over, the ISS commander, Jim Voss was elated and ready to show everyone what they had found with the help of the ULD.

No leaks were found around the closed hatch, but a line that recirculates the air pumped out of the crew lock back into the station was leaking at a connector.

One suspect capped feed through (Inter-module Ventilation Valve - #1 above) was looked at and determined to not be the leak source. With the leaking connector in the line identified, valves were shut to the line to stop the airflow. Now the mission could continue normally as if nothing were wrong. It became obvious why Ultrasonic Leak Detectors are used on over 10,000 periodic maintenance checks in the JSC Facilities – the tools are easy to use and can quickly determine where leaks or other problems are located.

From the Astronauts' point of view...

The crew returned and in their debrief revealed they had performed the leak check without even looking at the procedures. Somehow, the procedures were not immediately available when they needed them, but "it was simple to use" and "it was very obvious where the leak was and was not." STS-104 Shuttle Crew Commander Steve Riley said.

Below: International Space Station (ISS) Airlock
Bottom, right: Airlock Processing at Kennedy Space Center

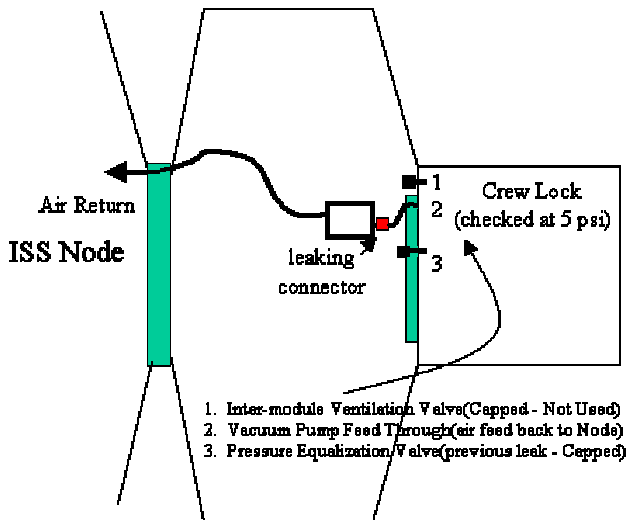

"The ULD really made his (Jim Voss – International Space Station Flight Engineer) day...he was like a kid in a candy store!" Jim even had some fun with it, Steve concluded, "before he put it away he used it to check for leaks in crew members!"

The ULD remains ready, testing continues.

As the ULD remains ready on the ISS with plenty of backup batteries for the next contingency, engineers in the Structures Engineering Division are testing the system for recording, repeatability and usefulness in periodic inspections of various Space Station Systems, including different sized leaks to vacuum such as a hole in a station module produced by a micro-meteoroid hit. Recently, the ULD was

certified to be used in the Russian modules as well as the US segment. The ULD is now being combined with a leak repair kit into one easily recognizable "ISS Leak Kit" bag that will contain all the equipment the crew will need in the event of a pressure leak emergency. In just over 6 months the tool went from possibly not flying to Station to becoming considered a tool critical to quickly finding leaks in an emergency.

What's Next?

Space Shuttle and Extravehicular engineers and operators have begun operational tests and building the case for keeping a ULD on each Orbiter mission for contingency purposes. Also, by combining Ultrasonic techniques with recent successes of stand-

alone micro-wireless instrumentation on the Space Shuttle missions, an autonomous Space Station module leak monitoring system will be developed to quickly locate the approximate location of dangerous leaks and enunciate them to the crew. The crew can then use the handheld unit to confirm and fix any leaking penetration with the leak repair kit. Demonstrations of the first prototype battery-powered micro-wireless Ultrasonic monitors have been completed. JSC Structures Engineering Division is also leading the international effort to define the requirements and implement the systems needed for both micro-meteorite damage detection, monitoring, and repair for the Space Station.



Above: Using the ULD to detect leaks on the International Space Station

For more information, contact CTRL Systems, Inc. at 1.410.876.5676 or e-mail info@ctrlsys.com.